

A

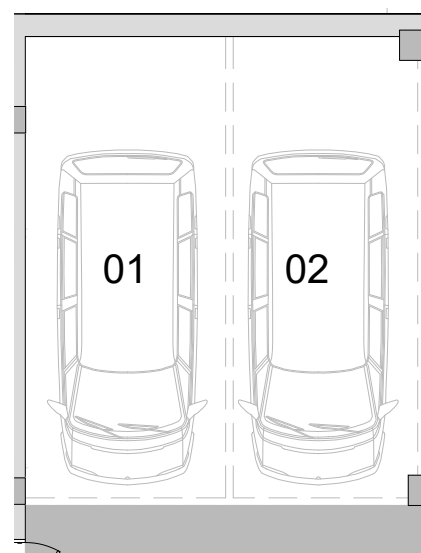

E: 1/100

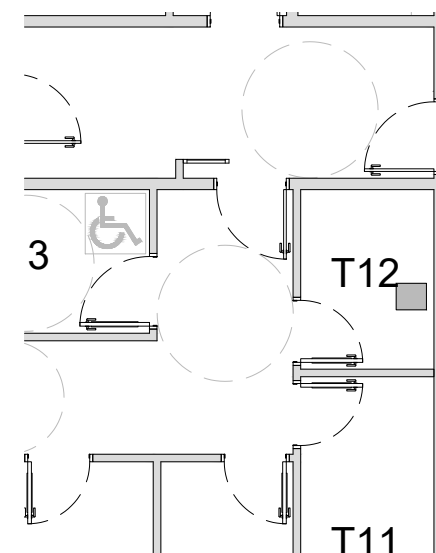

E: 1/100

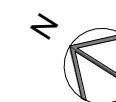

VIVIENDA	GARAJE	SUP. ÚTIL	TRASTERO	SUP. ÚTIL
C SS 1 A	2	26,61 m <sup>2</sup>	12	4,01 m <sup>2</sup>

SUP. ÚTIL INTERIOR		82,13 m <sup>2</sup>
SALÓN COMEDOR		25,74 m <sup>2</sup>
COCINA		9,86 m <sup>2</sup>
DORMITORIO PRINCIPAL		11,38 m <sup>2</sup>
DORMITORIO 2		9,21 m <sup>2</sup>
DORMITORIO 3		9,17 m <sup>2</sup>
BAÑO 1		2,70 m <sup>2</sup>
BAÑO 2		3,56 m <sup>2</sup>
VESTÍBULO		3,20 m <sup>2</sup>
DISTRIBUIDOR		7,31 m <sup>2</sup>
SUP. ÚTIL EXTERIOR		15,32 m <sup>2</sup>
TENDEDERO		1,96 m <sup>2</sup>
TERRAZA		13,36 m <sup>2</sup>

Superficies aproximadas.

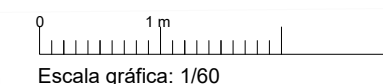

Escala gráfica: 1/60

**Edificio C**  
**Planta Semisótano -1 A**